



L78LxxAB L78LxxAC - L78LxxC

Positive voltage regulators

Features

- Output current up to 100 mA
- Output voltages of 3.3; 5; 6; 8; 9; 10; 12; 15; 18; 24 V
- Thermal overload protection
- Short circuit protection
- No external components are required
- Available in either $\pm 5\%$ (AC) or $\pm 10\%$ (C) selection

Description

The L78Lxx series of three-terminal positive regulators employ internal current limiting and thermal shutdown, making them essentially indestructible. If adequate heat-sink is provided, they can deliver up to 100 mA output current. They are intended as fixed voltage regulators in a wide range of applications including local or on-card regulation for elimination of noise and distribution problems associated with single-point regulation.

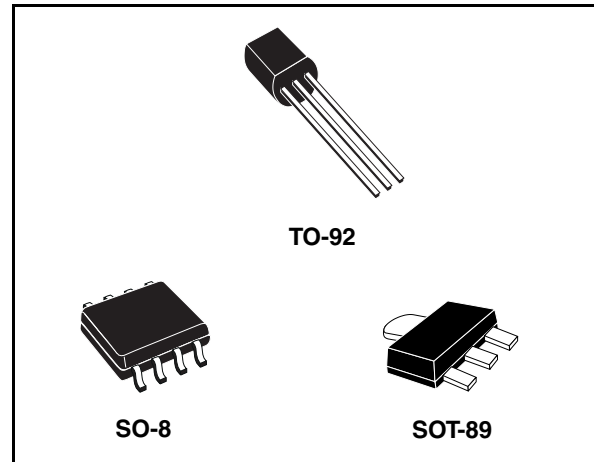

In addition, they can be used with power pass elements to make high-current voltage regulators. The L78Lxx series used as Zener diode/resistor combination replacement, offers an effective output impedance improvement of typically two orders of magnitude, along with lower quiescent current and lower noise.

Table 1. Device summary

Part numbers		
L78L33C	L78L08AC	L78L15C
L78L33AC	L78L08AB	L78L15AC
L78L33AB	L78L09C	L78L15AB
L78L05C	L78L09AC	L78L18C
L78L05AC	L78L09AB	L78L18AC
L78L05AB	L78L10AC	L78L24C
L78L06AC	L78L12C	L78L24AC
L78L06AB	L78L12AC	L78L24AB
L78L08C	L78L12AB	

3 Maximum ratings

Table 2. Absolute maximum ratings

Symbol	Parameter		Value	Unit
V_I	DC Input voltage	$V_O = 3.3$ to 9 V	30	V
		$V_O = 12$ to 15 V	35	
		$V_O = 18$ to 24 V	40	
I_O	Output current		100	mA
P_D	Power dissipation		Internally limited ⁽¹⁾	mW
T_{STG}	Storage temperature range		-65 to 150	°C
T_{OP}	Operating junction temperature range	for L78L00AC	0 to 150	°C
		for L78L00AB	-40 to 125	

- Our SO-8 package used for voltage regulators is modified internally to have pins 2, 3, 6 and 7 electrically commuted to the die attach flag. This particular frame decreases the total thermal resistance of the package and increases its ability to dissipate power when an appropriate area of copper on the printed circuit board is available for heat-sinking. The external dimensions are the same as for the standard SO-8.

Table 3. Thermal data

Symbol	Parameter	SO-8	TO-92	SOT-89	Unit
R_{thJC}	Thermal resistance junction-case. (Max)	20		15	°C/W
R_{thJA}	Thermal resistance junction-ambient. (Max)	55 ⁽¹⁾	200		°C/W

- Considering 6 cm² of copper Board heat-sink.

Table 13. Electrical characteristics of L78L33AB and L78L33AC (refer to the test circuits, $V_I = 8.3\text{ V}$, $I_O = 40\text{ mA}$, $C_I = 0.33\text{ }\mu\text{F}$, $C_O = 0.1\text{ }\mu\text{F}$, $T_J = 0\text{ to }125^\circ\text{C}$ for L78L33AC, $T_J = -40\text{ to }125^\circ\text{C}$ for L78L33AB, unless otherwise specified)

Symbol	Parameter	Test conditions	Min.	Typ.	Max.	Unit
V_O	Output voltage	$T_J = 25^\circ\text{C}$	3.168	3.3	3.432	V
V_O	Output voltage	$I_O = 1\text{ to }40\text{ mA}$, $V_I = 5.3\text{ to }20\text{ V}$	3.135		3.465	V
		$I_O = 1\text{ to }70\text{ mA}$, $V_I = 8.3\text{ V}$	3.135		3.465	
ΔV_O	Line regulation	$V_I = 5.3\text{ to }20\text{ V}$, $T_J = 25^\circ\text{C}$			150	mV
		$V_I = 6.3\text{ to }20\text{ V}$, $T_J = 25^\circ\text{C}$			100	
ΔV_O	Load regulation	$I_O = 1\text{ to }100\text{ mA}$, $T_J = 25^\circ\text{C}$			60	mV
		$I_O = 1\text{ to }40\text{ mA}$, $T_J = 25^\circ\text{C}$			30	
I_d	Quiescent current	$T_J = 25^\circ\text{C}$			6	mA
		$T_J = 125^\circ\text{C}$			5.5	mA
ΔI_d	Quiescent current change	$I_O = 1\text{ to }40\text{ mA}$			0.1	mA
		$V_I = 6.3\text{ to }20\text{ V}$			1.5	
eN	Output noise voltage	$B = 10\text{ Hz to }100\text{ kHz}$, $T_J = 25^\circ\text{C}$		40		μV
SVR	Supply voltage rejection	$V_I = 6.3\text{ to }16.3\text{ V}$, $f = 120\text{ Hz}$ $I_O = 40\text{ mA}$, $T_J = 25^\circ\text{C}$	41	49		dB
V_d	Dropout voltage			1.7		V

Table 14. Electrical characteristics of L78L05AB and L78L05AC (refer to the test circuits, $V_I = 10\text{ V}$, $I_O = 40\text{ mA}$, $C_I = 0.33\text{ }\mu\text{F}$, $C_O = 0.1\text{ }\mu\text{F}$, $T_J = 0\text{ to }125^\circ\text{C}$ for L78L05AC, $T_J = -40\text{ to }125^\circ\text{C}$ for L78L05AB, unless otherwise specified)

Symbol	Parameter	Test conditions	Min.	Typ.	Max.	Unit
V_O	Output voltage	$T_J = 25^\circ\text{C}$	4.8	5	5.2	V
V_O	Output voltage	$I_O = 1\text{ to }40\text{ mA}$, $V_I = 7\text{ to }20\text{ V}$	4.75		5.25	V
		$I_O = 1\text{ to }70\text{ mA}$, $V_I = 10\text{ V}$	4.75		5.25	
ΔV_O	Line regulation	$V_I = 7\text{ to }20\text{ V}$, $T_J = 25^\circ\text{C}$			150	mV
		$V_I = 8\text{ to }20\text{ V}$, $T_J = 25^\circ\text{C}$			100	
ΔV_O	Load regulation	$I_O = 1\text{ to }100\text{ mA}$, $T_J = 25^\circ\text{C}$			60	mV
		$I_O = 1\text{ to }40\text{ mA}$, $T_J = 25^\circ\text{C}$			30	
I_d	Quiescent current	$T_J = 25^\circ\text{C}$			6	mA
		$T_J = 125^\circ\text{C}$			5.5	mA
ΔI_d	Quiescent current change	$I_O = 1\text{ to }40\text{ mA}$			0.1	mA
		$V_I = 8\text{ to }20\text{ V}$			1.5	
eN	Output noise voltage	$B = 10\text{ Hz to }100\text{ kHz}$, $T_J = 25^\circ\text{C}$		40		μV
SVR	Supply voltage rejection	$V_I = 8\text{ to }18\text{ V}$, $f = 120\text{ Hz}$ $I_O = 40\text{ mA}$, $T_J = 25^\circ\text{C}$	41	49		dB
V_d	Dropout voltage			1.7		V

Table 21. Electrical characteristics of L78L18AC (refer to the test circuits, $V_I = 27\text{ V}$, $I_O = 40\text{ mA}$, $C_I = 0.33\text{ }\mu\text{F}$, $C_O = 0.1\text{ }\mu\text{F}$, $T_J = 0\text{ to }125^\circ\text{C}$ for L78L18AC, $T_J = -40\text{ to }125^\circ\text{C}$ for L78L18AB, unless otherwise specified)

Symbol	Parameter	Test conditions	Min.	Typ.	Max.	Unit
V_O	Output voltage	$T_J = 25^\circ\text{C}$	17.3	18	18.7	V
V_O	Output voltage	$I_O = 1\text{ to }40\text{ mA}$, $V_I = 22\text{ to }33\text{ V}$	17.1		18.9	V
		$I_O = 1\text{ to }70\text{ mA}$, $V_I = 27\text{ V}$	17.1		18.9	
ΔV_O	Line regulation	$V_I = 22\text{ to }33\text{ V}$, $T_J = 25^\circ\text{C}$			320	mV
		$V_I = 22\text{ to }33\text{ V}$, $T_J = 25^\circ\text{C}$			270	
ΔV_O	Load regulation	$I_O = 1\text{ to }100\text{ mA}$, $T_J = 25^\circ\text{C}$			170	mV
		$I_O = 1\text{ to }40\text{ mA}$, $T_J = 25^\circ\text{C}$			85	
I_d	Quiescent current	$T_J = 25^\circ\text{C}$			6.5	mA
		$T_J = 125^\circ\text{C}$			6	mA
ΔI_d	Quiescent current change	$I_O = 1\text{ to }40\text{ mA}$			0.1	mA
		$V_I = 23\text{ to }33\text{ V}$			1.5	
eN	Output noise voltage	$B = 10\text{ Hz to }100\text{ kHz}$, $T_J = 25^\circ\text{C}$		120		μV
SVR	Supply voltage rejection	$V_I = 23\text{ to }33\text{ V}$, $f = 120\text{ Hz}$ $I_O = 40\text{ mA}$, $T_J = 25^\circ\text{C}$	33	38		dB
V_d	Dropout voltage			1.7		V

Table 22. Electrical characteristics of L78L24AB and L78L24AC (refer to the test circuits, $V_I = 33\text{ V}$, $I_O = 40\text{ mA}$, $C_I = 0.33\text{ }\mu\text{F}$, $C_O = 0.1\text{ }\mu\text{F}$, $T_J = 0\text{ to }125^\circ\text{C}$ for L78L24AC, $T_J = -40\text{ to }125^\circ\text{C}$ for L78L24AB, unless otherwise specified)

Symbol	Parameter	Test conditions	Min.	Typ.	Max.	Unit
V_O	Output voltage	$T_J = 25^\circ\text{C}$	23	24	25	V
V_O	Output voltage	$I_O = 1\text{ to }40\text{ mA}$, $V_I = 27\text{ to }38\text{ V}$	22.8		25.2	V
		$I_O = 1\text{ to }70\text{ mA}$, $V_I = 33\text{ V}$	22.8		25.2	
ΔV_O	Line regulation	$V_I = 27\text{ to }38\text{ V}$, $T_J = 25^\circ\text{C}$			350	mV
		$V_I = 28\text{ to }38\text{ V}$, $T_J = 25^\circ\text{C}$			300	
ΔV_O	Load regulation	$I_O = 1\text{ to }100\text{ mA}$, $T_J = 25^\circ\text{C}$			200	mV
		$I_O = 1\text{ to }40\text{ mA}$, $T_J = 25^\circ\text{C}$			100	
I_d	Quiescent current	$T_J = 25^\circ\text{C}$			6.5	mA
		$T_J = 125^\circ\text{C}$			6	mA
ΔI_d	Quiescent current change	$I_O = 1\text{ to }40\text{ mA}$			0.1	mA
		$V_I = 28\text{ to }38\text{ V}$			1.5	
eN	Output noise voltage	$B = 10\text{ Hz to }100\text{ kHz}$, $T_J = 25^\circ\text{C}$		200		μV
SVR	Supply voltage rejection	$V_I = 29\text{ to }33\text{ V}$, $f = 120\text{ Hz}$ $I_O = 40\text{ mA}$, $T_J = 25^\circ\text{C}$	31	37		dB
V_d	Dropout voltage			1.7		V

TO-92 mechanical data

Dim.	mm.			mils.		
	Min.	Typ.	Max.	Min.	Typ.	Max.
A	4.32		4.95	170.1		194.9
b	0.36		0.51	14.2		20.1
D	4.45		4.95	175.2		194.9
E	3.30		3.94	129.9		155.1
e	2.41		2.67	94.9		105.1
e1	1.14		1.40	44.9		55.1
L	12.7		15.49	500.0		609.8
R	2.16		2.41	85.0		94.9
S1	0.92		1.52	36.2		59.8
W	0.41		0.56	16.1		22.0
α		5°			5°	

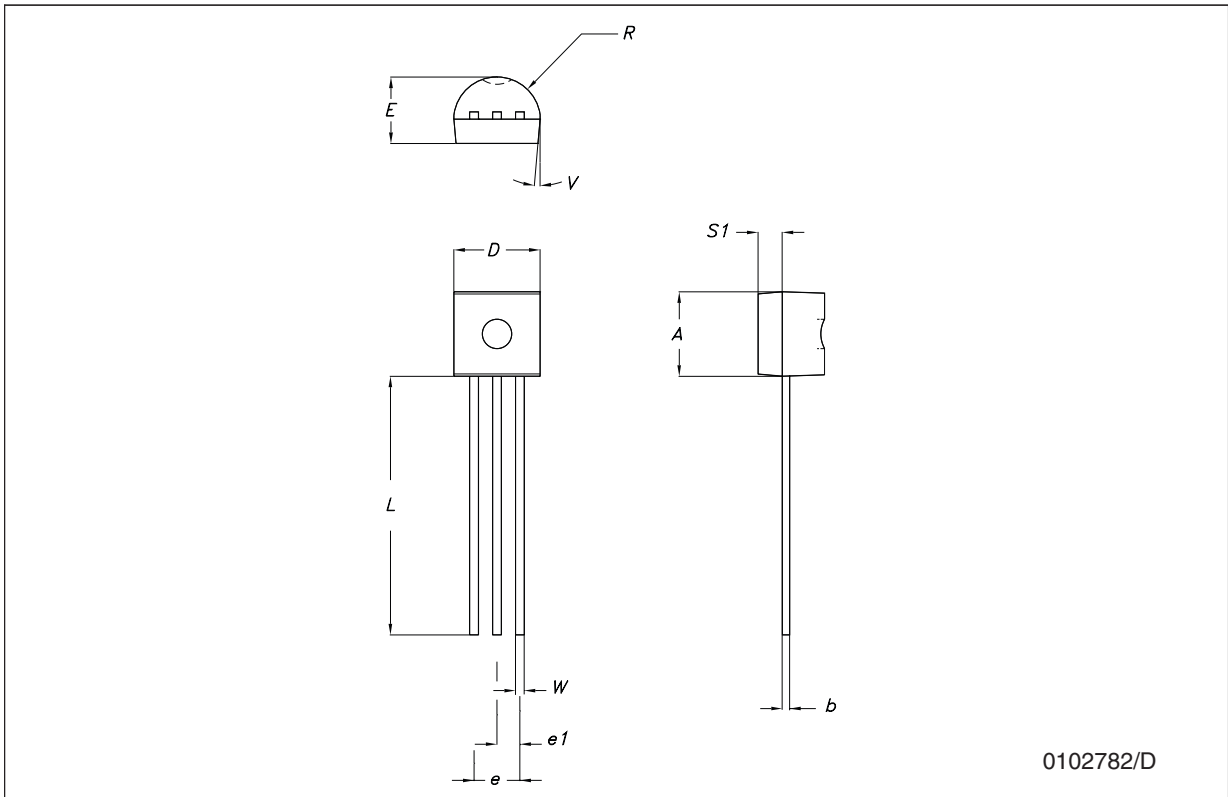

Tape & reel for TO-92 mechanical data

Dim.	mm.			inch.		
	Min.	Typ.	Max.	Min.	Typ.	Max.
A1		4.80			0.189	
T		3.80			0.150	
T1		1.60			0.063	
T2		2.30			0.091	
d		0.48			0.019	
P0	12.5		12.9	0.492		0.508
P2	5.65		7.05	0.222		0.278
F1, F2	2.44	2.54	2.94	0.096	0.100	0.116
delta H		±2			0.079	
W	17.5	18.00	19.0	0.689	0.709	0.748
W0	5.7		6.3	0.224		0.248
W1	8.5		9.25	0.335		0.364
W2		0.50			0.20	
H		18.50	18.70		0.728	0.726
H0	15.50		16.50	0.610		0.650
H1		25.00			0.984	
D0	3.8		4.2	0.150		0.165
t		0.90			0.035	
L1		3			0.118	
delta P		±1			0.039	
u		50			1.968	
Φ1		360			14.173	
Φ2		30			1.181	

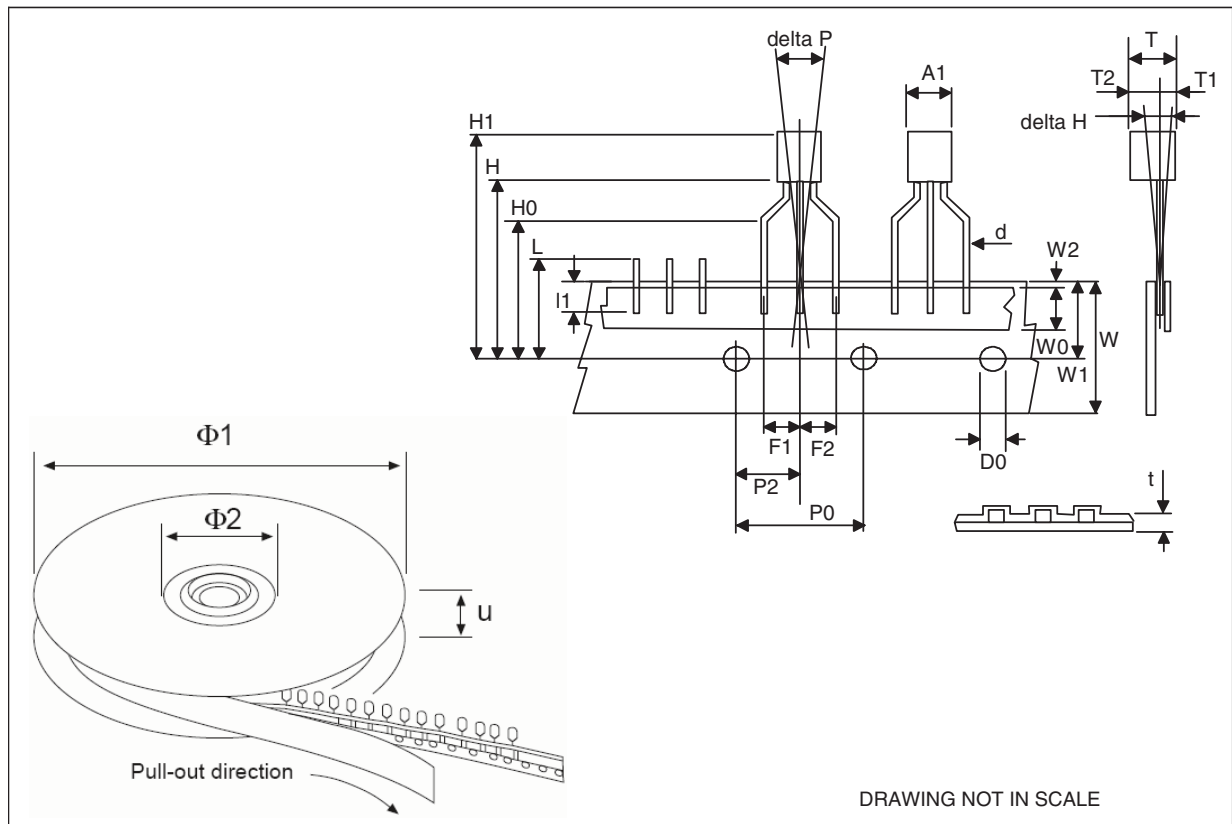

8 Order codes

Table 23. Order codes

Part numbers	Packaging			Output voltage
	SO-8	TO92 (BAG) ⁽¹⁾	SOT-89	
L78L33C	L78L33CD-TR			3.3 V
L78L33AC	L78L33ACD13TR	L78L33ACZ	L78L33ACUTR	3.3 V
L78L33AB	L78L33ABD-TR	L78L33ABZ	L78L33ABUTR	3.3 V
L78L05C	L78L05CD13TR	L78L05CZ		5 V
L78L05AC	L78L05ACD13TR	L78L05ACZ	L78L05ACUTR	5 V
L78L05AB	L78L05ABD13TR	L78L05ABZ	L78L05ABUTR	5 V
L78L06AC	L78L06ACD13TR	L78L06ACZ	L78L06ACUTR	6 V
L78L06AB	L78L06ABD13TR	L78L06ABZ	L78L06ABUTR	6 V
L78L08C	L78L08CD13TR			8 V
L78L08AC	L78L08ACD13TR	L78L08ACZ	L78L08ACUTR	8 V
L78L08AB	L78L08ABD13TR	L78L08ABZ	L78L08ABUTR	8 V
L78L09C	L78L09CD13TR			9 V
L78L09AC	L78L09ACD13TR	L78L09ACZ	L78L09ACUTR	9 V
L78L09AB	L78L09ABD13TR	L78L09ABZ	L78L09ABUTR	9 V
L78L10AC			L78L10ACUTR	10 V
L78L12C	L78L12CD13TR			12 V
L78L12AC	L78L12ACD13TR	L78L12ACZ	L78L12ACUTR	12 V
L78L12AB	L78L12ABD-TR	L78L12ABZ	L78L12ABUTR	12 V
L78L15C	L78L15CD-TR			15 V
L78L15AC	L78L15ACD13TR	L78L15ACZ	L78L15ACUTR	15 V
L78L15AB		L78L15ABZ	L78L15ABUTR	15 V
L78L18C	L78L18CD13TR			18 V
L78L18AC	L78L18ACD13TR		L78L18ACUTR	18 V
L78L24C	L78L24CD-TR			24 V
L78L24AC	L78L24ACD-TR	L78L24ACZ	L78L24ACUTR	24 V
L78L24AB	L78L24ABD13TR	L78L24ABZ	L78L24ABUTR	24 V

1. Available in Ammopak with the suffix "-AP" or in Tape & Reel with the suffix "TR". Please note that in these cases pins are shaped according to Tape & Reel specifications.